



# INSTALLATION INSTRUCTIONS

Accessory  
**TRAILER HITCH**

Application  
**2016 ODYSSEY**

Publications No.  
**VERSION 1**

Issue Date  
**JULY 2015**

## PARTS LIST

### Trailer Hitch Kit P/N 08L92-TK8-100

Trailer hitch

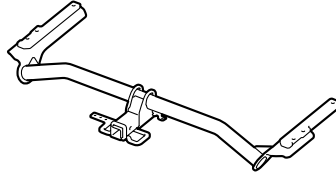

Ball mount

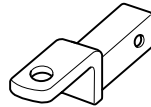

Hitch pin

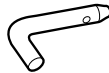

Hitch pin clip



Receiver cover

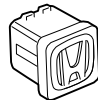

6 Hex bolts



6 Plain washers



5 Clips



Bumper edge trim

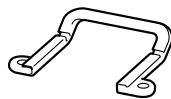

### Trailer Hitch Harness Kit P/N 08L91-TK8-100

Control unit harness

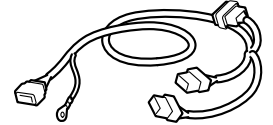

Socket harness

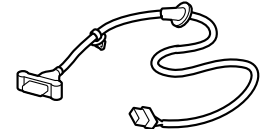

Control unit bracket



Control unit

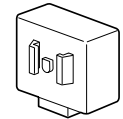

EPT sealer

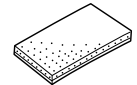

11 Wire ties

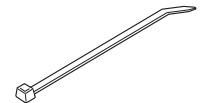

2 Flange bolts



Fuse (10A)

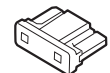

2 Fuses (7.5A)

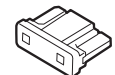

**ATF Cooler Kit (Sold separately)  
P/N 06255-RV0-306**

ATF Cooler

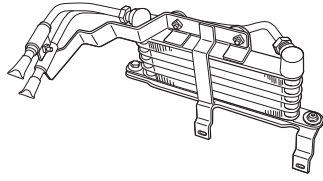

ATF Hose (265 mm)



ATF Hose (335 mm)  
(Not used in 2014 models)



ATF Hose (295 mm)



3 Washer-bolts (6 x 12 mm)



4 Hose clamps



Hose spacer (5 A/T)



Mirror hang-tag



**TOOLS AND SUPPLIES REQUIRED**

- Phillips screwdriver
- Flat-tip screwdriver
- Ratchet
- 6 mm and 12 mm Sockets
- Trim Tool Set (T/N SOJATP2014)
- Diagonal cutters
- Torque wrench
- Drill
- 3 mm and 10 mm Drill bits
- Blanket
- Eye protection (safety goggles, face shield, etc.)
- Isopropyl alcohol
- Shop towel
- Air saw (Snap on AT192A)
- Pushpin
- File
- 10 mm Open end wrench
- Hex wrench
- Masking tape
- Pliers

***Illustration of the Trailer Hitch on the Vehicle***

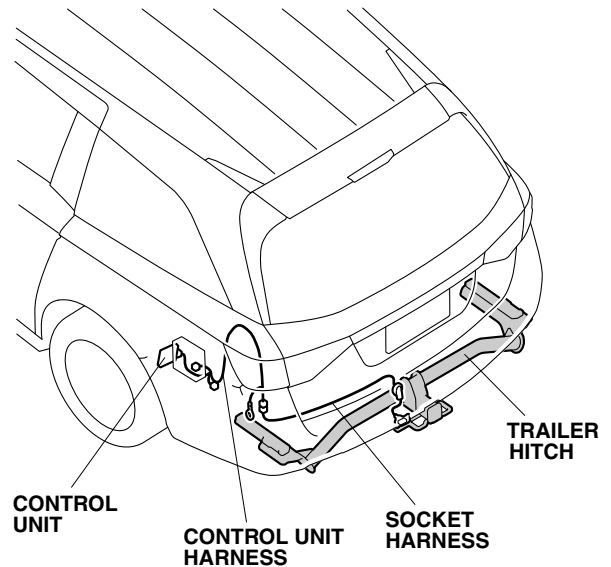

## INSTALLATION

**Customer Information:** The information in this installation instruction is intended for use only by skilled technicians who have the proper tools, equipment, and training to correctly and safely add equipment to your vehicle. These procedures should not be attempted by “do-it-yourselfers.”

### NOTE:

- Allow the engine and transmission to cool down before installing the ATF cooler.
  - Be careful not to damage the finished surfaces of the body.
  - Install the backup sensors before installing the trailer hitch.
  - Do not damage the body paint finish.
1. Make sure you have the anti-theft code for the audio unit and navigation system (if equipped), then write down the radio station presets.
  2. Remove the air duct (two clips).

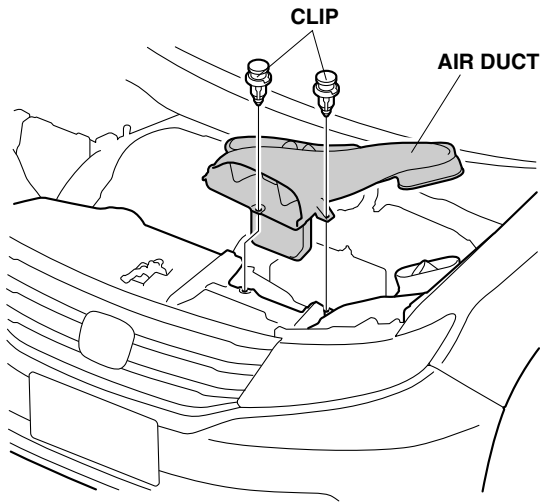

3. Disconnect the negative cable from the battery.

4. Remove the driver's sliding door sill trim (five clips, six retaining tabs, and two hooks).

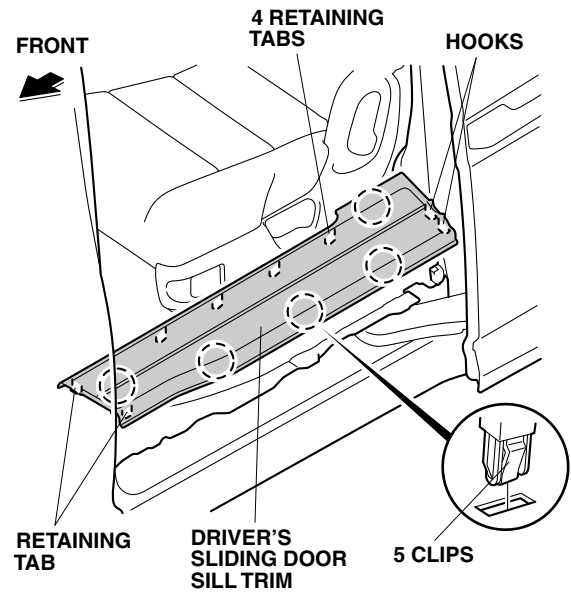

5. Remove the rear trim panel.
  - Using a shop towel and pliers, remove two threaded hooks.

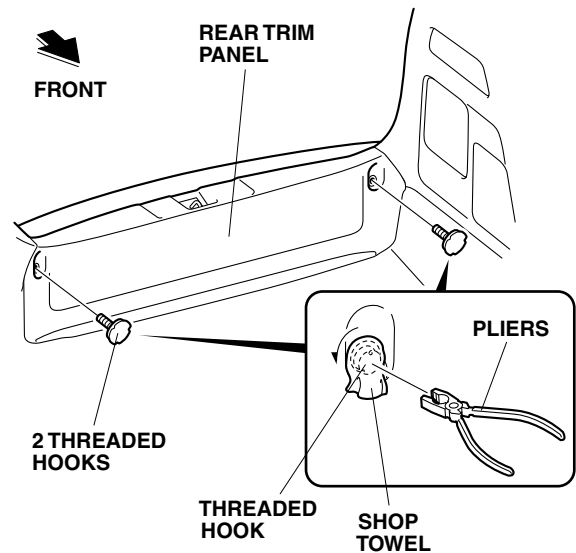

- Pull away the weatherstrip from around the rear trim panel.

- Gently pull out on the rear trim panel to release eight clips and four retaining tabs, and remove the rear trim panel.

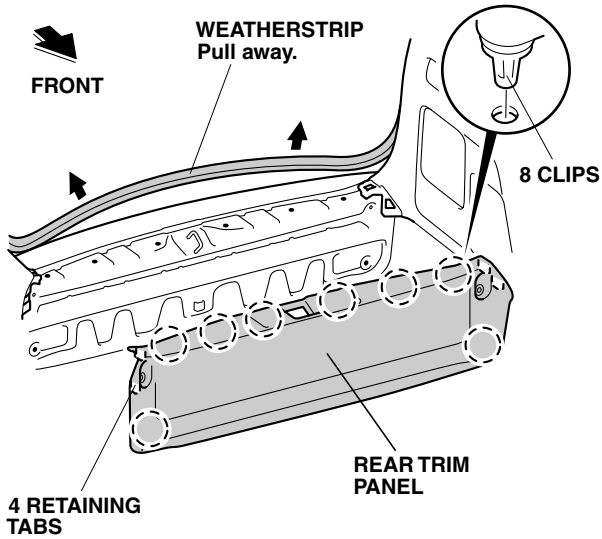

- Pull away the weatherstrip from around the rear of the driver's side rear trim panel.

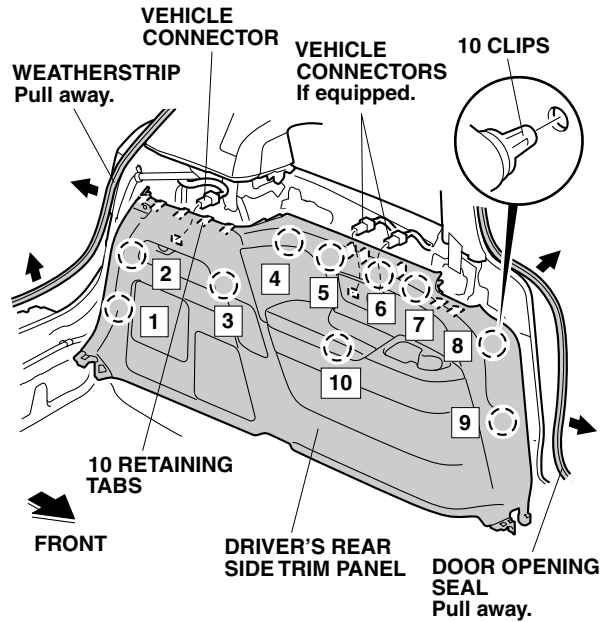

6. Remove the driver's side rear trim panel.
  - Using a shop towel and pliers, remove the threaded hook.

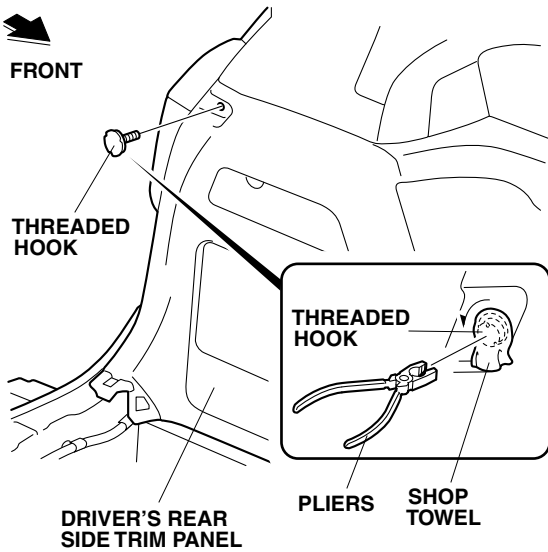

- Pull away the door opening seal from around the front of the driver's side rear trim panel.
- Gently pull out on the driver's side rear trim panel to release ten clips and ten retaining tabs.
- Unplug the vehicle connector, and remove the driver's side rear trim panel. If the vehicle is equipped with other vehicle connectors, unplug the vehicle connectors.

- Fold down the third row seat.

7. On each side, attach masking tape to the rear bumper, taillight, and rear fender as shown.

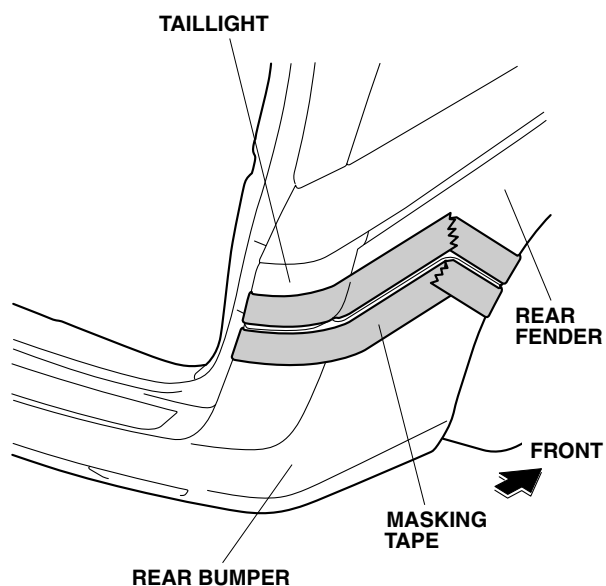

8. Remove the rear bumper.
  - Remove six self-tapping screws, four hex bolts, and five clips.

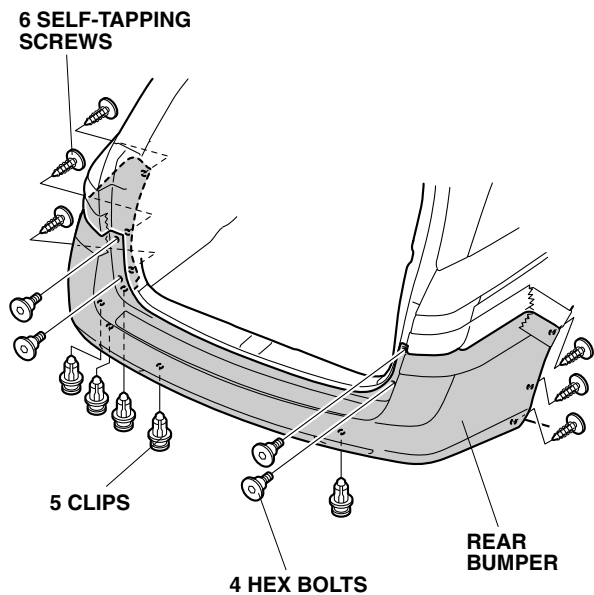

- Release nine retaining tabs on each side.

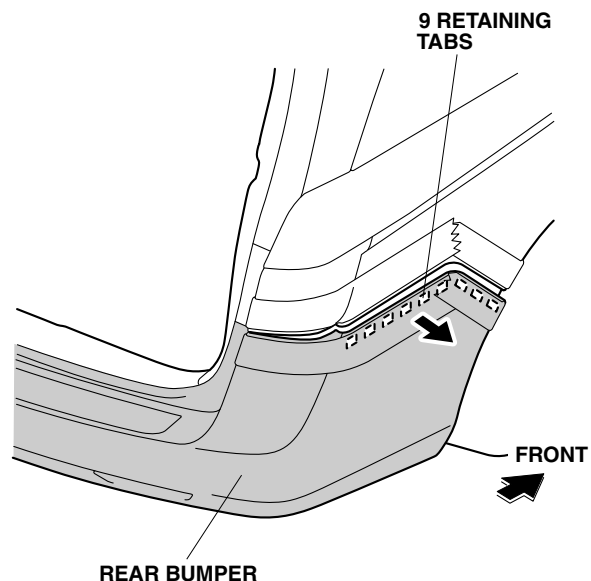

- Have an assistant help you when removing the rear bumper.
- Place the rear bumper on a blanket after removal.

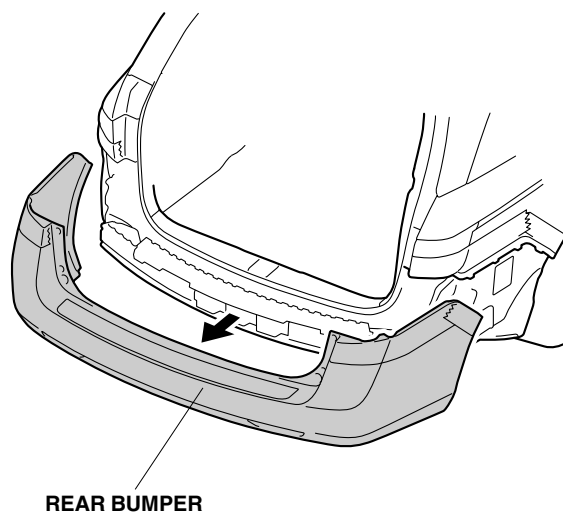

- Remove the vehicle grommet from the rear panel and discard it.

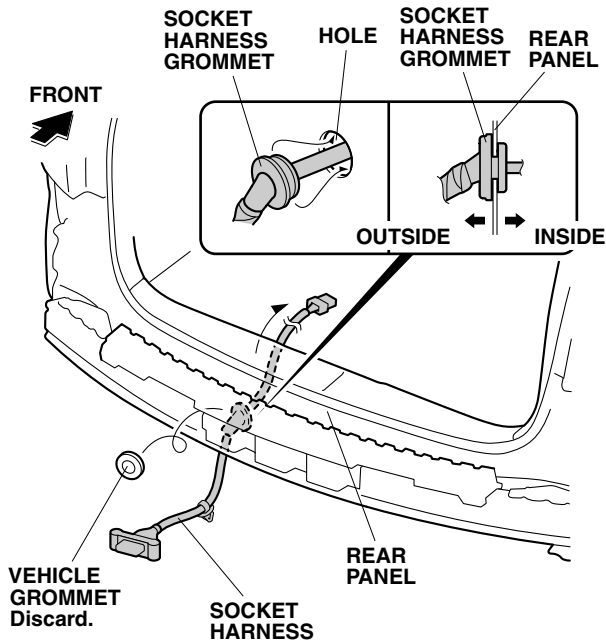

- Route the 4-pin connector end of the socket harness from the outside to the inside of the vehicle. Install the socket harness grommet into the rear panel.
- Inside in the vehicle, use isopropyl alcohol on a shop towel to thoroughly clean the rear panel where the EPT sealer will attach.

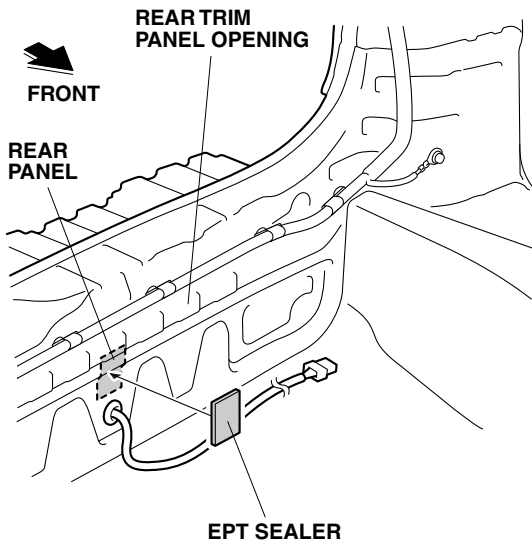

- Attach the EPT sealer to the rear panel as shown.

- Route the socket harness along the vehicle harness and secure it to the vehicle harness with three wire ties.

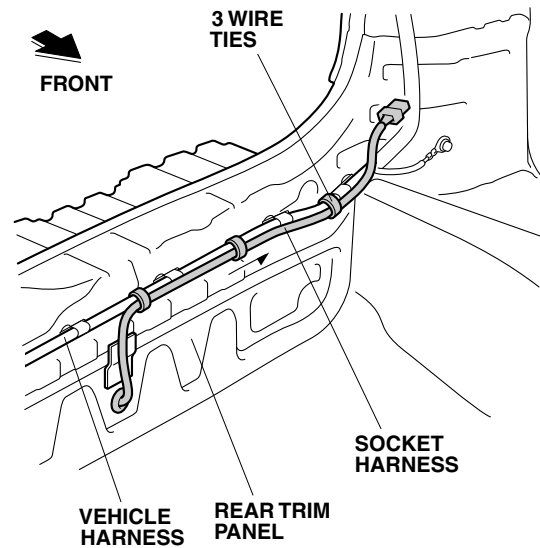

- Plug the control unit harness 4-pin connector to the socket harness 4-pin connector.

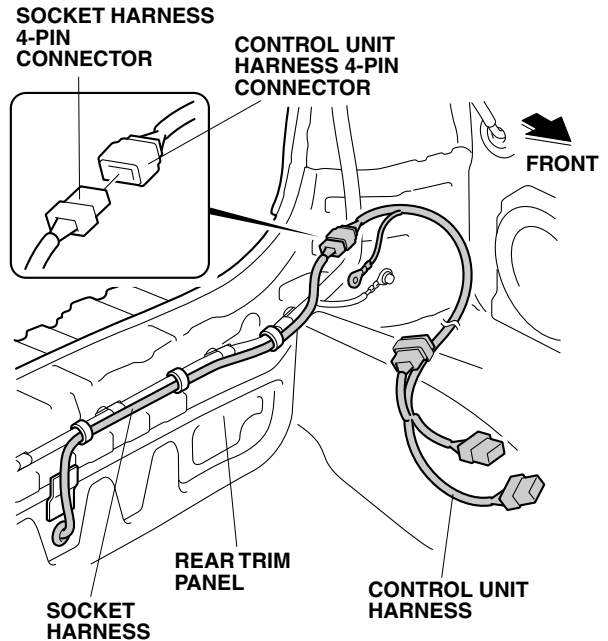

- Remove the vehicle ground bolt.

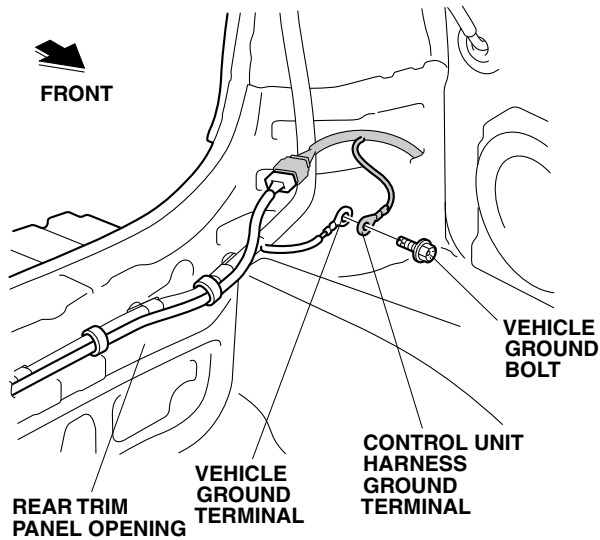

- Secure the control unit harness ground terminal and the vehicle ground terminal with the vehicle ground bolt removed step in 15.
- Route the control unit harness along the vehicle harness. Secure the 4-pin connectors and control unit harness to the vehicle harness with six wire ties.

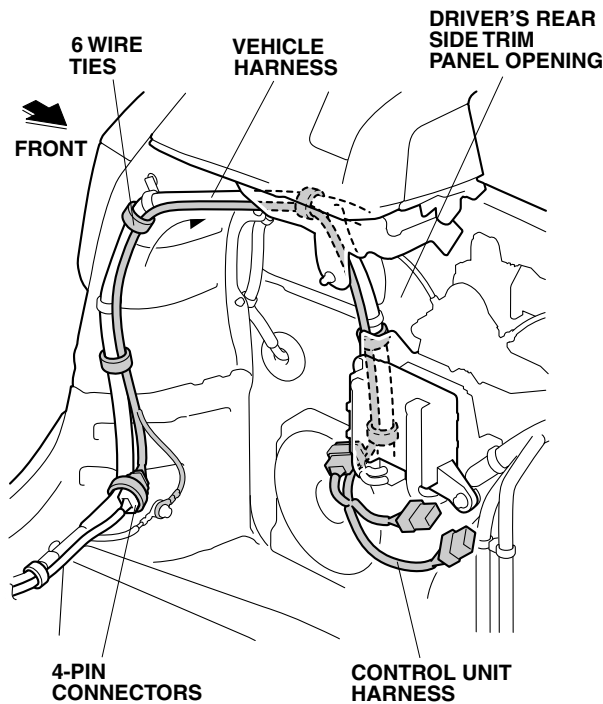

*If the vehicle is equipped with accessory backup sensors, go to step 18. If not, go to step 20.*

### With Accessory Backup Sensors

- Unplug the accessory backup sensor harness 14-pin connector from the rear fuse box.

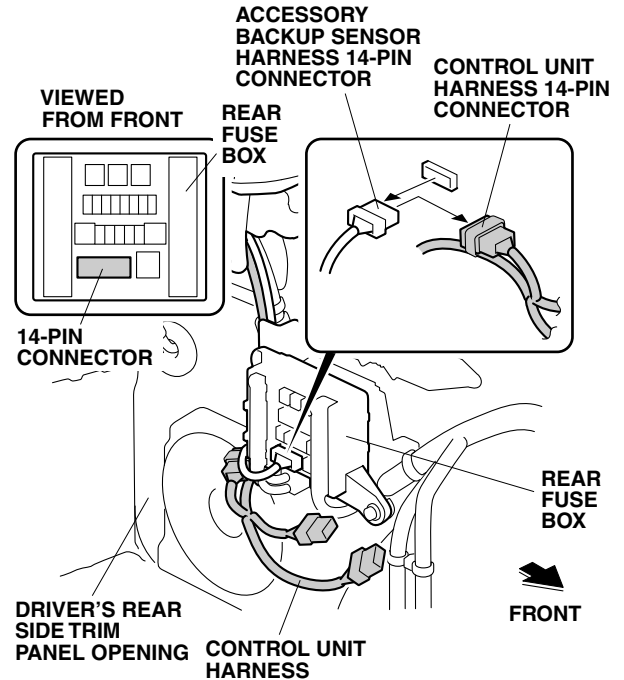

- Plug the accessory backup sensor harness 14-pin connector into the control unit harness 14-pin connector.

20. Plug the control unit harness 14-pin connector to the 14-pin opening in the rear fuse box.

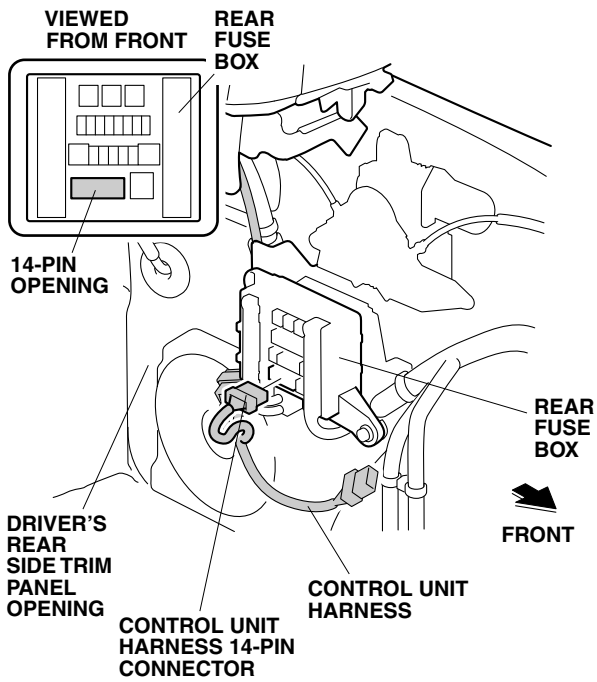

21. Install the control unit onto the control unit bracket.

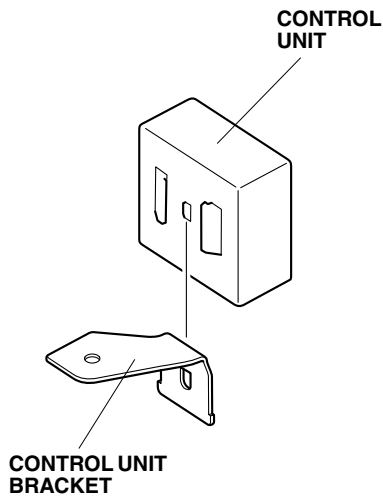

22. Remove one fuse box bolt from the rear fuse box.

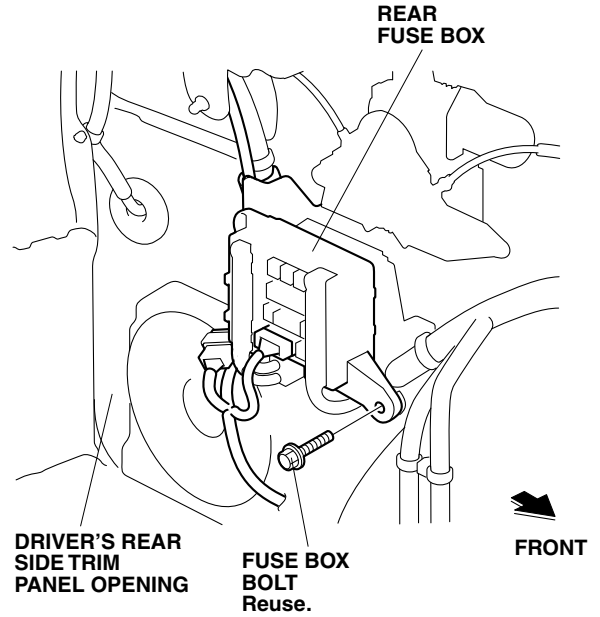

23. Install the control unit to the vehicle panel with the fuse box bolt removed step in 22.

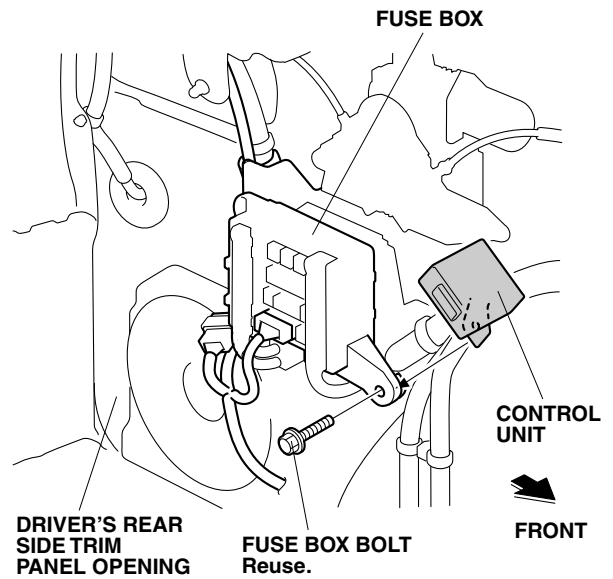



24. Plug the control unit harness 12-pin connector into the control unit.

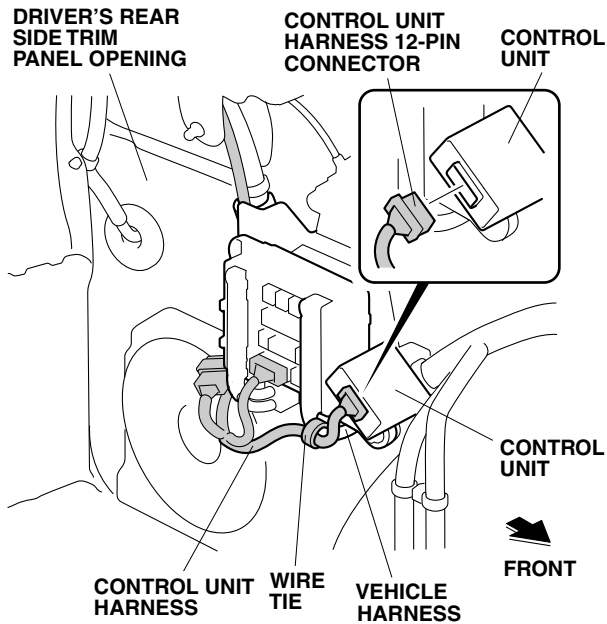

25. Secure the control unit harness to the vehicle harness with one wire tie.
26. Install one 10A fuse into the rear fuse box as shown. If a 10A fuse is already installed in the fuse box in the slot, go to step 27.

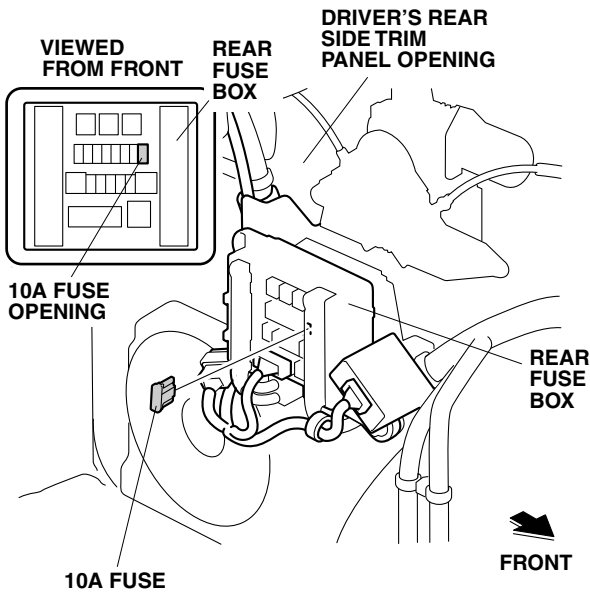

27. Install two 7.5A fuses into the rear fuse box as shown. If two 7.5A fuses are already installed in the fuse box in the slots, go to step 28.

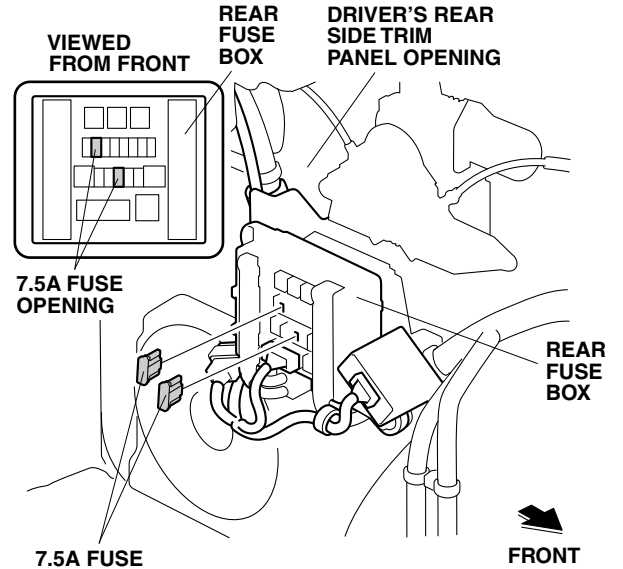

28. Release the rubber mount from the muffler. NOTE: Be careful not to damage the muffler.

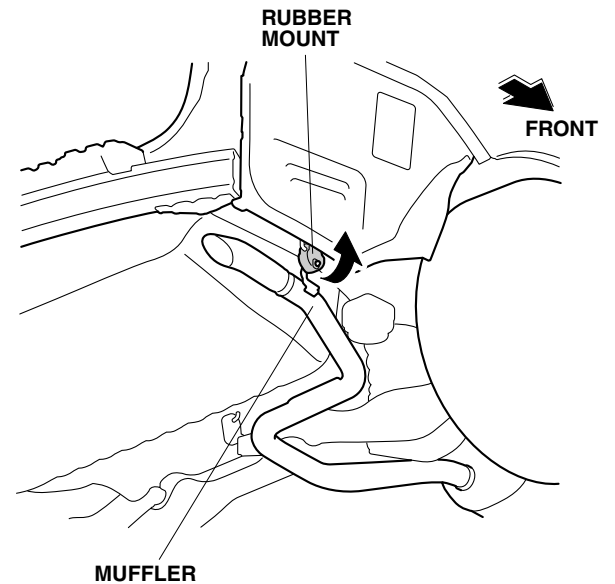

29. Install the trailer hitch to the vehicle frame with six plain washers and six hex bolts.  
**NOTE:** Have an assistant help you when installing the trailer hitch. Torque the hex bolts: 80 N·m (59 lbf·ft).

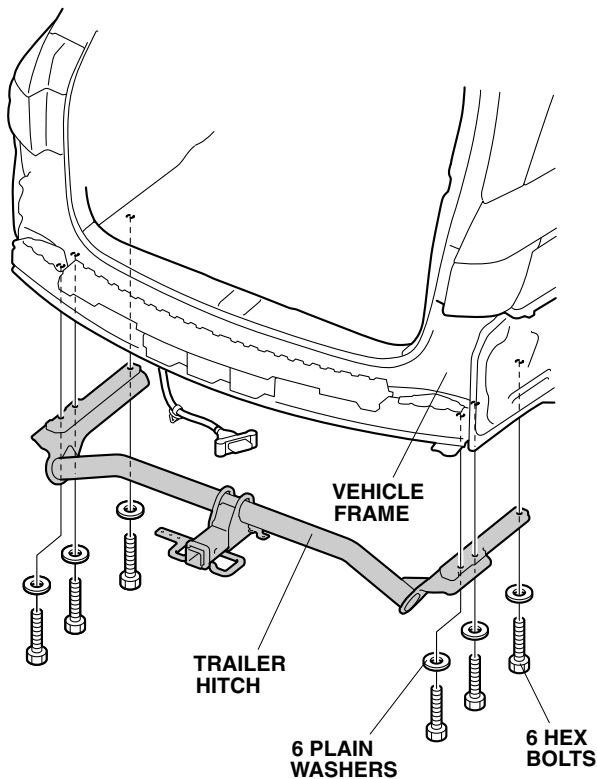

30. Reinstall the rubber mount to the muffler.  
 31. Inside the rear bumper, locate four scribe marks. Using a pushpin, pierce the center of each scribe mark on the rear bumper as shown.

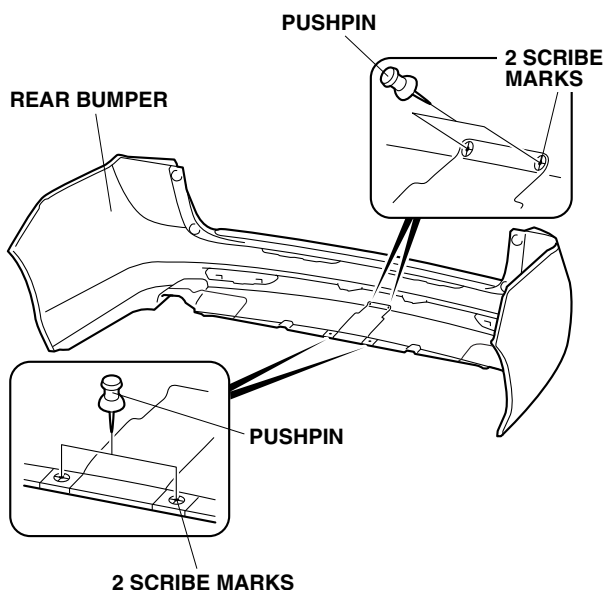

32. While wearing eye protection, drill the front two pierced marks in the rear bumper. First drill with a 3 mm drill bit, and finish with a 10 mm drill bit. Remove any burrs.

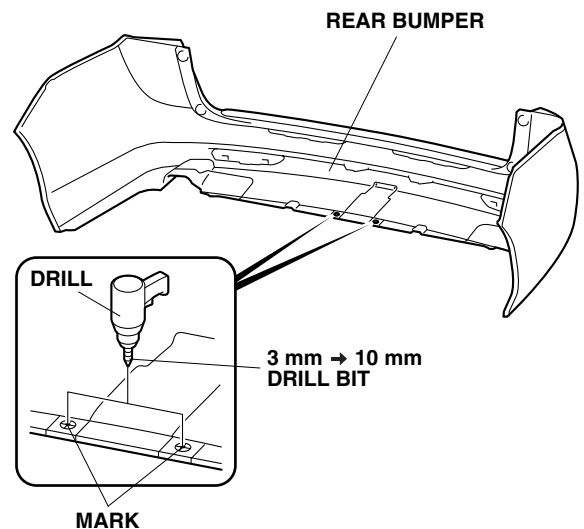

33. Drill the rear two pierced marks in the rear bumper. First drill with a 3 mm drill bit, and finish with a 10 mm drill bit.

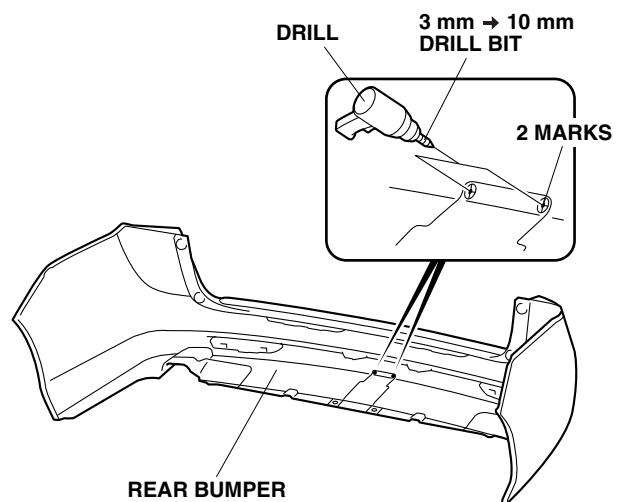

34. Using an air saw, cut the rear bumper along the scribe line as shown. Remove any burrs.

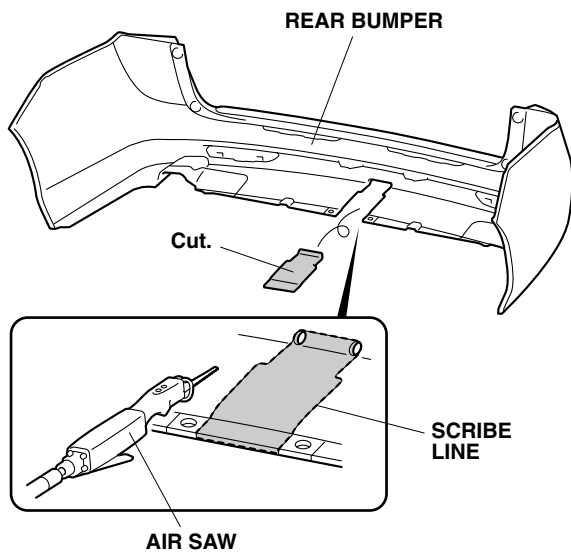

35. Install the bumper edge trim to the rear bumper.

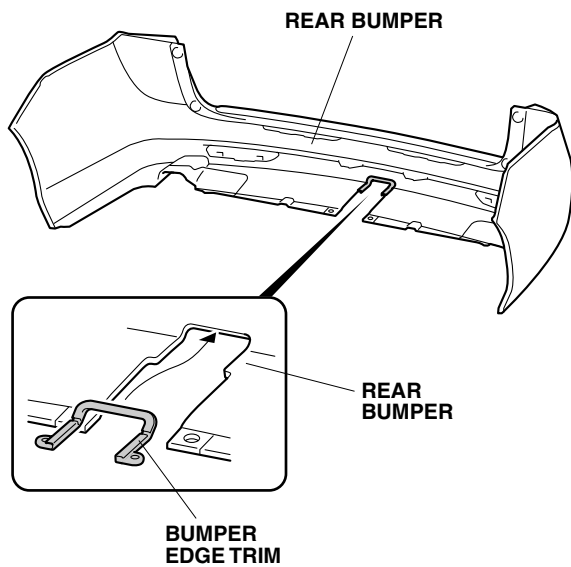

36. Using a felt-tip pen, mark the centers of the bumper edge trim holes.

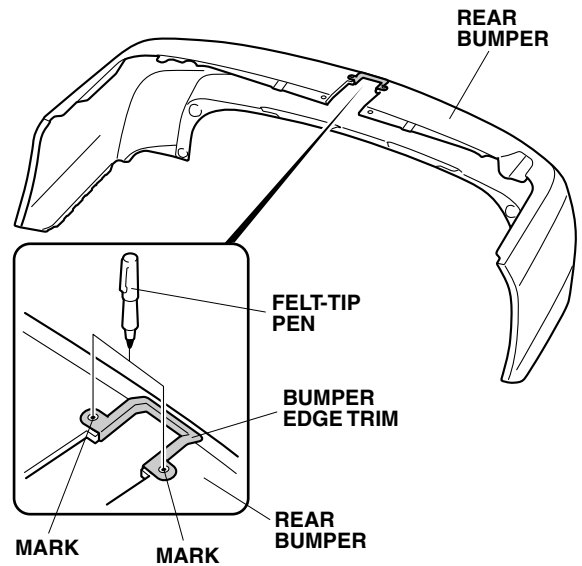

37. Remove the bumper edge trim.  
38. Using a pushpin, pierce the two marks on the rear bumper.

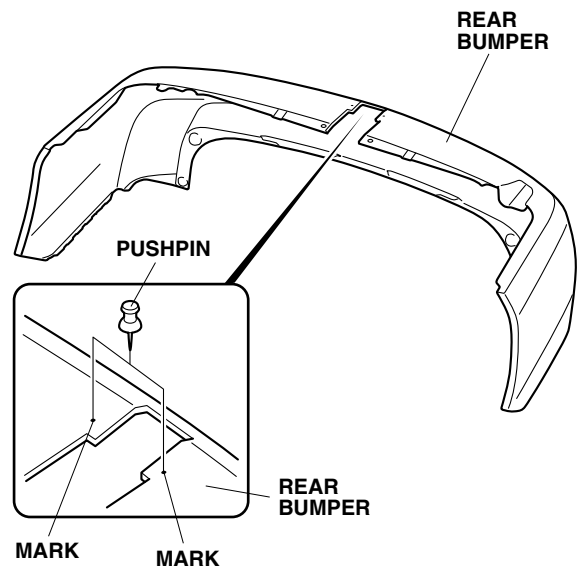

39. While wearing eye protection, drill the rear bumper. First drill with a 3 mm drill bit, and finish with a 10 mm drill bit. Remove any burrs.

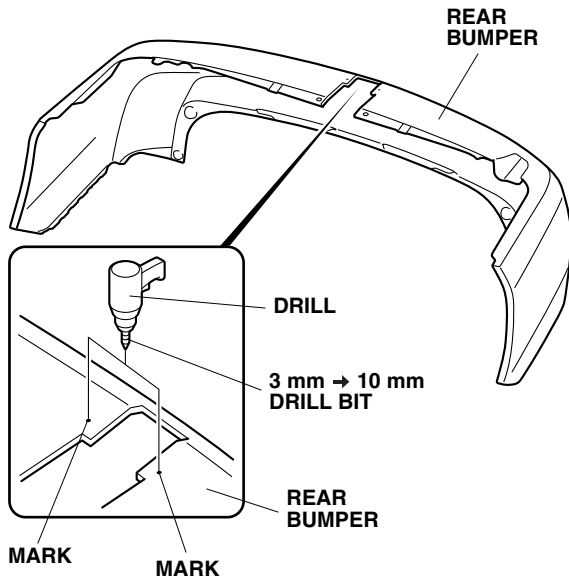

40. Attach the bumper edge trim to the rear bumper with two clips.

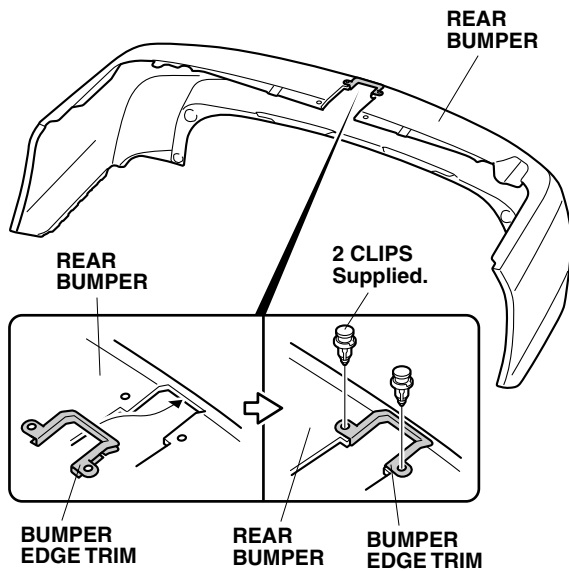

41. While wearing eye protection, use an air saw to cut the rear bumper along the scribe line as shown. Remove any burrs.

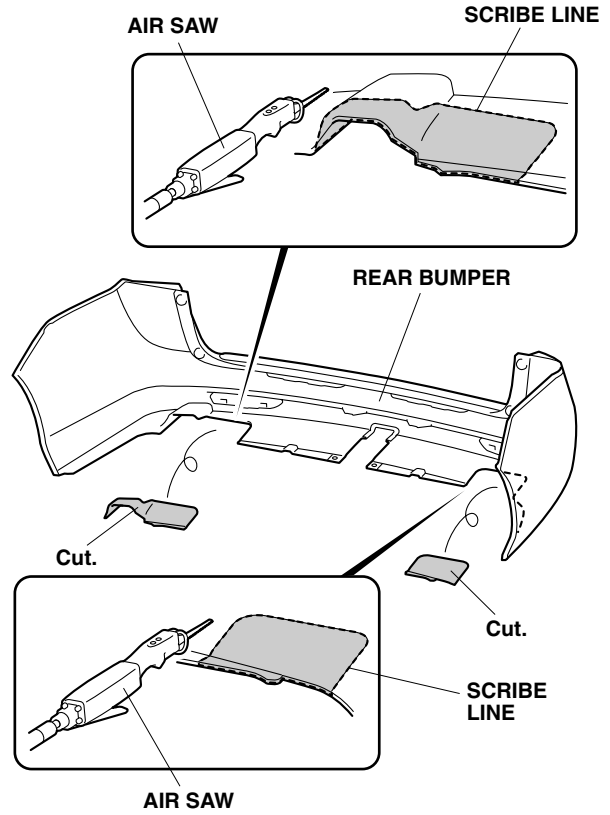

42. Secure the socket harness to the trailer hitch with two flange bolts. Make sure that the socket harness is in the correct position and orientation.

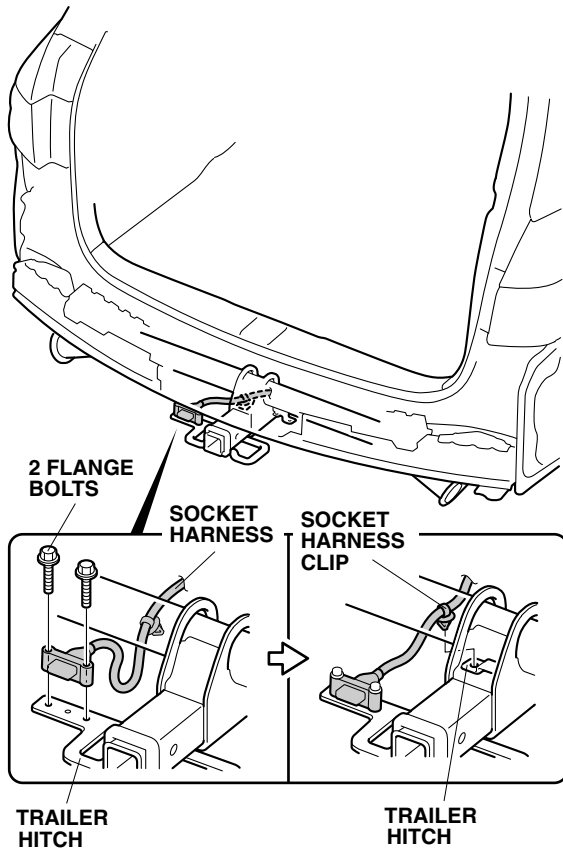

43. Secure the socket harness to the trailer hitch with the socket harness clip.

44. Reinstall the rear bumper.  
NOTE: Have an assistant help you when installing the rear bumper.

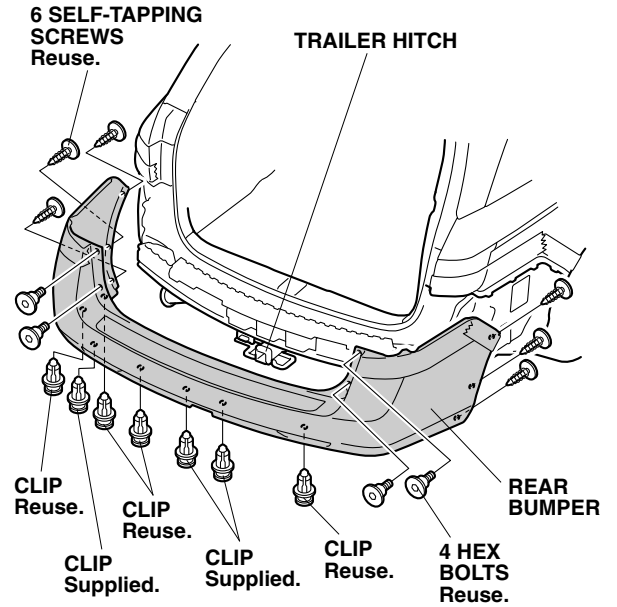

45. Secure the ball mount to the trailer hitch with the hitch pin and one hitch pin clip.

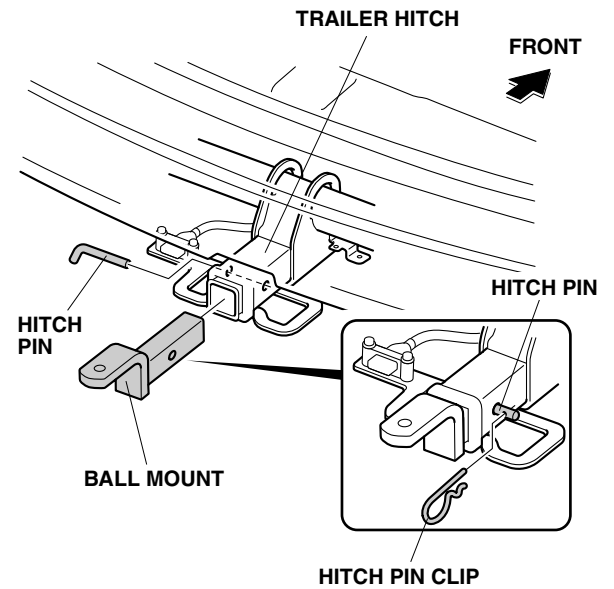

46. Check that all wire harnesses are routed properly and all connectors are plugged in.
47. Reinstall all removed parts.
48. Reconnect the negative cable to the battery.
49. Enter the customer's anti-theft code for the radio and navigation system (if equipped), and reset the radio station presets.
50. Reset the clock.

**Installing The ATF Cooler (Sold separately)**

**NOTE: Before starting work, allow the ATF lines and the surrounding parts to cool.**

51. Remove the front grille cover.

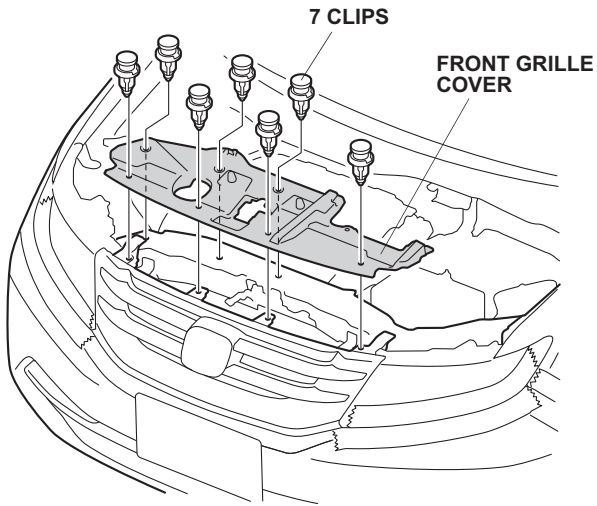

52. Remove the front bumper.

- On each side, attach masking tape to the areas shown.

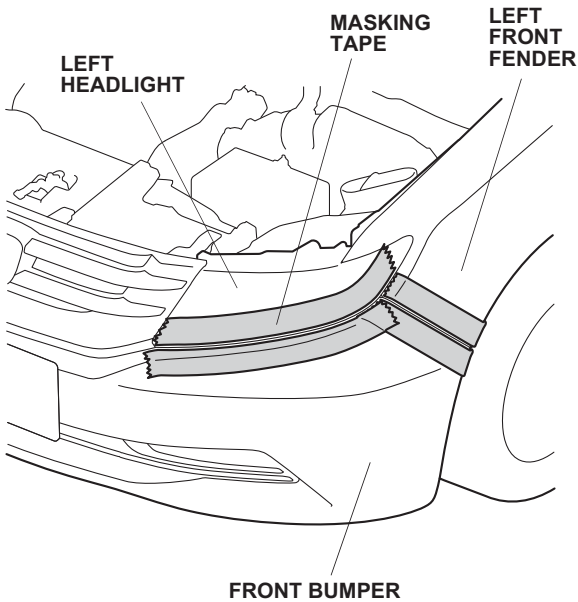

- Remove four self-tapping screws, eight bolts, and the four clips from the front bumper.

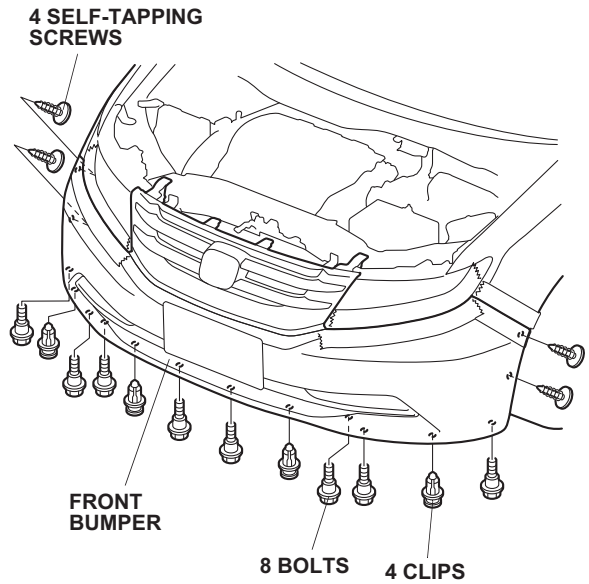

- Remove the front splash shield (six bolts and eleven clips).

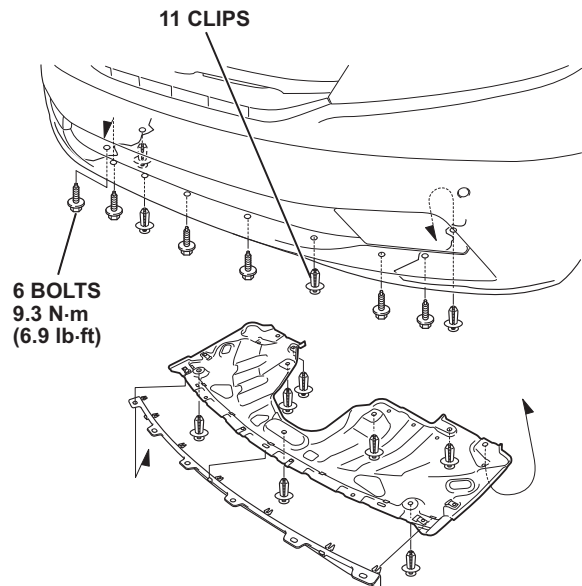

- Release eight retaining tabs on each side.

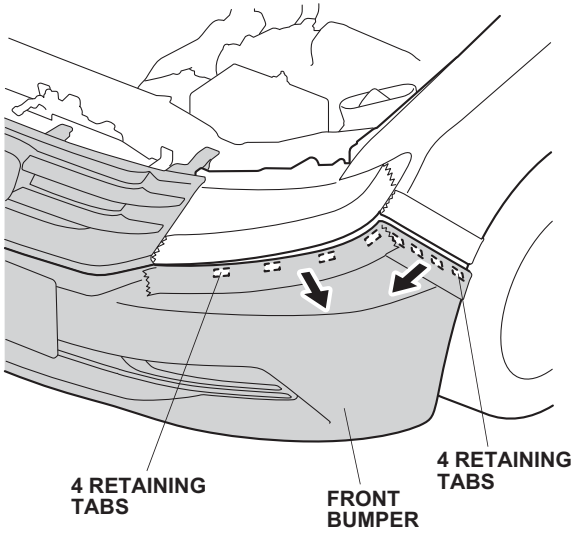

- Remove two top bolts from the front bumper. With the help of an assistant, remove the front bumper. Place the front bumper on a blanket.

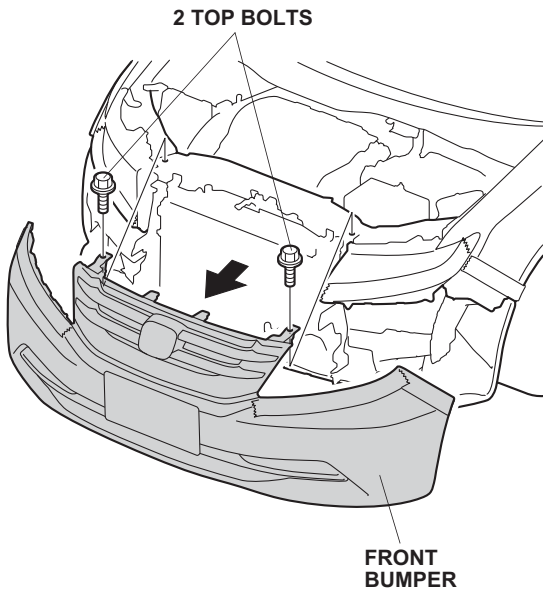

53. Remove the left headlight assembly.
  - Remove one clip and three bolts, then pull the headlight out slightly.
  - Remove the harness clips from the headlight housing, and disconnect the connectors from the bulb sockets.

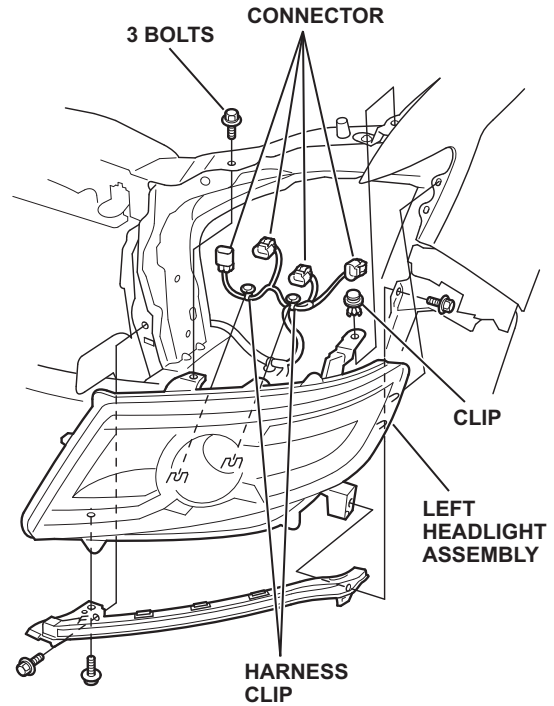

54. Remove the A/C condenser upper mount brackets (two bolts).

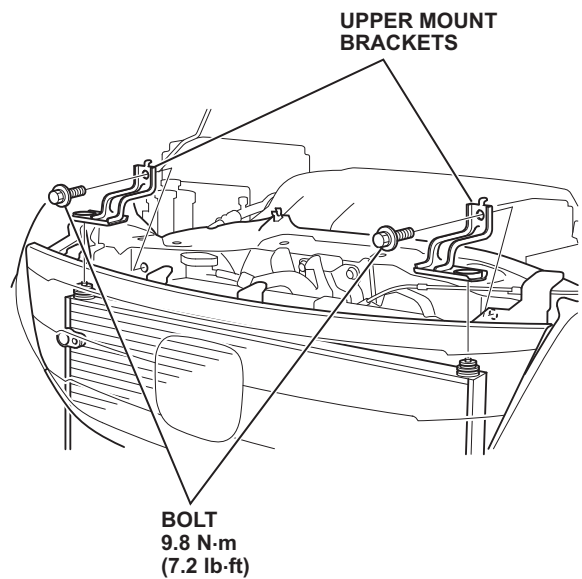

55. Remove the two bolts from the power steering line.

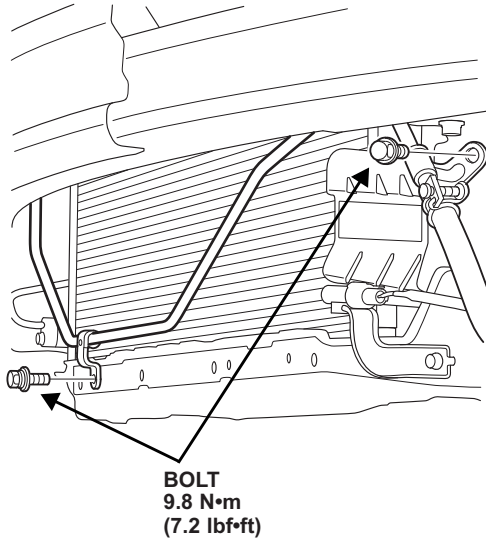

56. Detach the clips, then remove the left air guide.

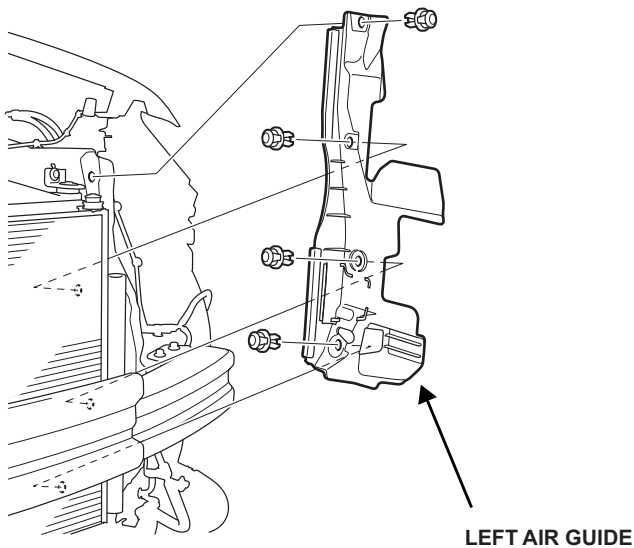

57. Cut the left air guide along the lines as shown. Then remove and discard the cut piece.

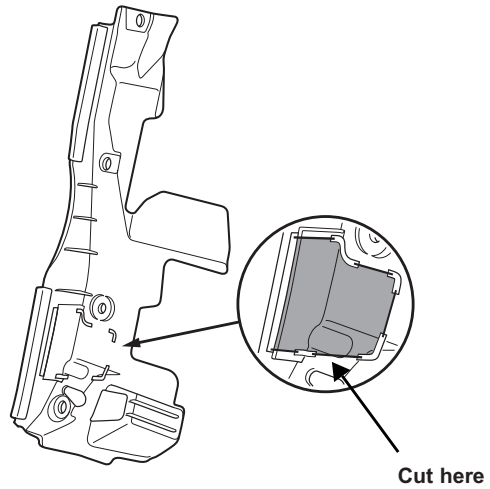

58. Install the left air guide.

59. Assemble the ATF cooler.

**NOTE:** Apply ATF when installing the hoses. When connecting the hoses, make sure to insert the hose until it is against the bulge in the pipe. Install each hose clamp with the edge of the clip located 7 mm from the end of the hose.

- Get the ATF hoses, the ATF cooler and the two hose clamps from the kit.
- Attach the 295 mm hose to the upper pipe of the ATF cooler with a clamp.
- Attach the 265 mm hose to the lower pipe of the ATF cooler with a clamp.

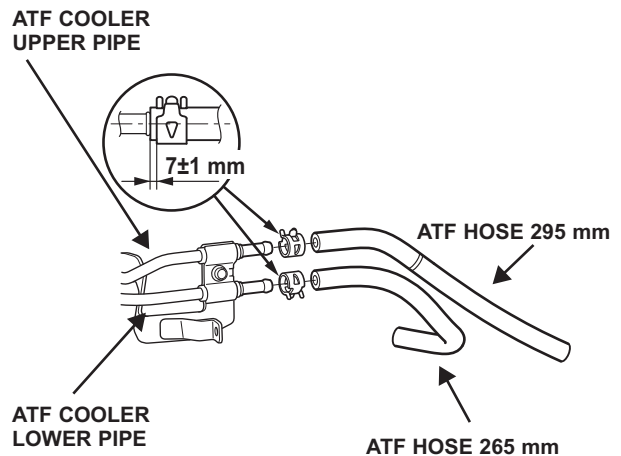



60. Route the hoses installed on the ATF cooler through the hole cut in the left air guide, and fit the ATF cooler into place on the bulkhead. Install the three washer-bolts from the kit through the ATF cooler into the threaded holes in the front bulkhead. Tighten the bolts securely.

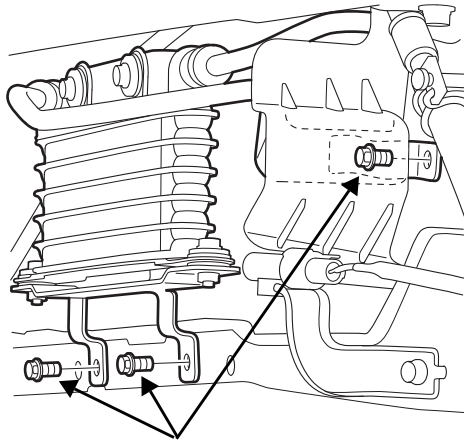

6 x12 mm WASHER-BOLT  
9.8 N•m  
(1.0 kgf•m, 7.2 lbf•ft)

61. Raise the vehicle on a lift.

- Remove the hose that connects the ATF filter and ATF pipe C, and put plugs in both the ATF filter and ATF pipe C to prevent leaks.

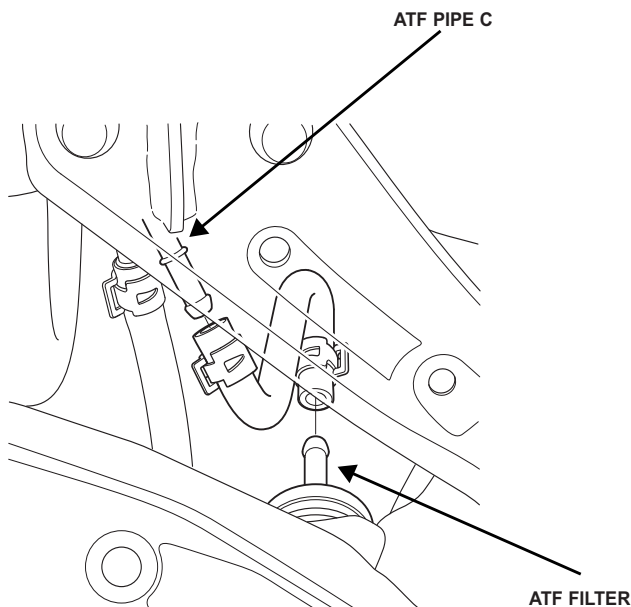

62. Connect the ATF cooler hoses.

NOTE: When installing the hose clamps, make sure they do not interfere with the surrounding parts.

- Remove the plug from the ATF filter, and connect the ATF cooler upper hose. Install the hose clamp. Align the paint marks as shown.

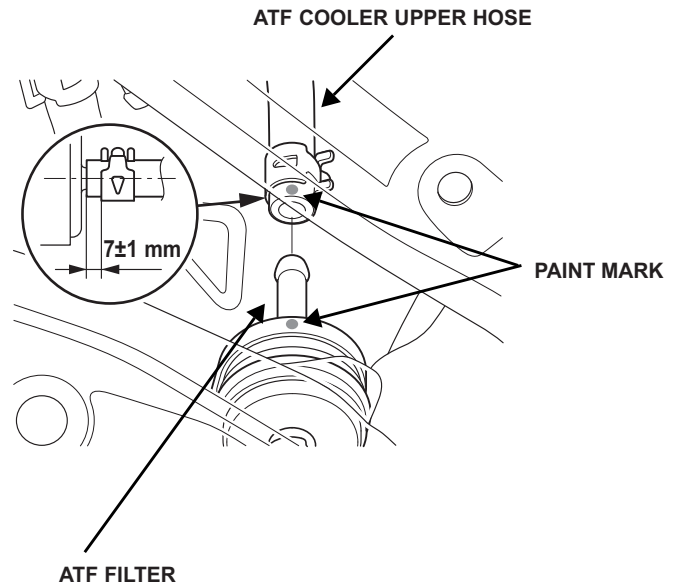

- Remove the plug from ATF pipe C, and connect the ATF cooler lower hose. Install the hose clamp.

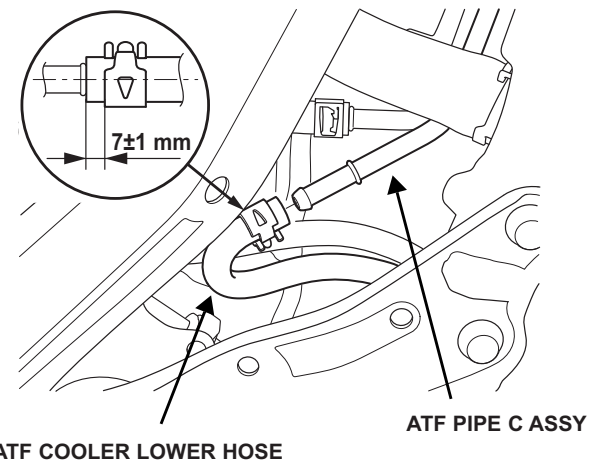

63. Install the power steering line mounting bolts.  
64. Install the A/C condensor upper mount brackets.  
65. Install the left headlight assembly.  
66. Install the front splash shield.  
67. Install the front bumper and the front grille cover.  
68. Check the ATF fluid level and fill as required.  
69. Install the hang-tag around the rearview mirror.

Give a copy of this page to your customer

### Installing the Receiver Cover

Whenever you remove the hitch pin clip, the hitch pin, and the ball mount, store them securely in the cargo area. Install the receiver cover into the opening at the end of the trailer hitch.

When you reinstall the ball mount, store the receiver cover in the cargo area.

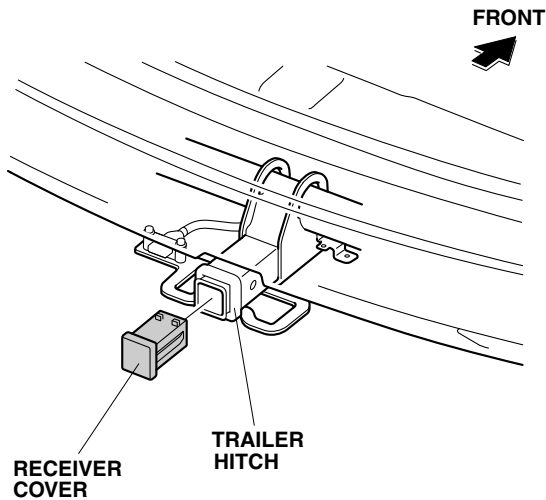

Install the ball mount to the trailer hitch using a hitch pin clip and hitch pin.

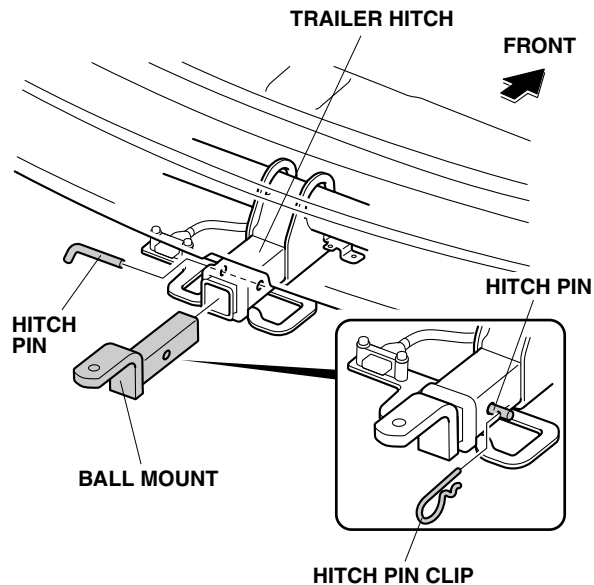

After the first 600 miles (1,000 km) of towing, have your Honda Dealer re-check the tightness of the trailer hitch bolts.

